

IO391 RELAY PCB CONNECTIONS Revision 01.03

Relays controlled directly by TTL or Open collector control (via P2) or by uP control (via P4, IC2 installed).
 For uP control, relay PCBs installed within same housing as uP PCB (cables between PCBs as short as possible).

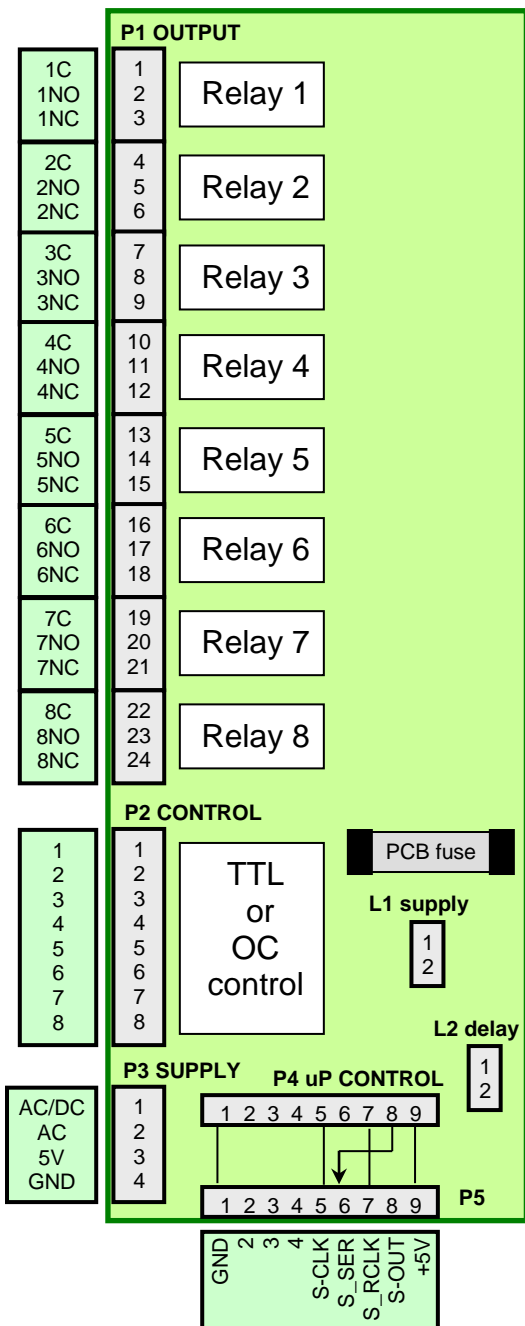

L1 selects TTL supply from on-board regulator, via AC supply (P3-3 and P4-9 not connected).
 L1 not installed, TTL supply from P3-3 or P4-9.

Relays supply from 12VAC (P3-1, P3-2) or 12VDC (12V connected to P3-1, P3-4 to GND).

L2 power-up delay on S-RCLK.
 Installed if only one IO391 or on last

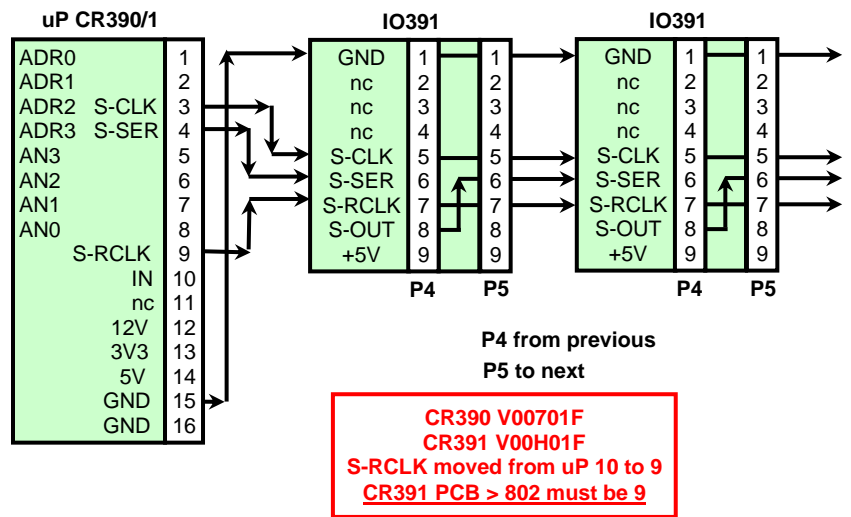

uP Control: Up to 6 Relay PCB daisy chained to uP
 S-CLK and S-RCLK parallel.
 S-OUT loop through to S-SER
 P4 from controller / previous IO391
 P5 to next IO391

On CR390/1, set output expanders (1 to 6)

On PC, output ports are 15 to 22 (1st expander),
 23 to 30 (2nd expander), etc.